



# Pratt Burnerd Key Operated KC Series Manual Collet Chucks



- ⚙ Two-year warranty
- ⚙ .001" repeatability
- ⚙ Capacities from 1/16" through 2 1/2"
- ⚙ Precision manufactured to fit types A, D and L spindles and adapter recess
- ⚙ Steel components are hardened and ground
- ⚙ Simple operation. No drawbar or actuating cylinder required
- ⚙ Accurate - .0002" TRI from rear mounting register working collet taper
- ⚙ Use PBA Multi-Size Collets 1/8" range per collet. Collets have 6 gripping blades and can be for round or hexagon stock

Chuck Size	Capacity	Uses Collet Type	Adapter Recess Model No.	Type A Spindle		Type D Spindle		Type L Spindle	
				Spindle Size	Chuck Model No.	Spindle Size	Chuck Model No.	Spindle Size	Chuck Model No.
KC15	1/16" - 1-1/2"	EC	KC15/AP (6010-01300)	A-5	6011-31300	D-3	6012-21300	L-00	6013-11300
				A-6	6011-41300	D-4	6012-31300	L-0	6013-21300
						D-5	6012-41300		
						D-6	6012-51300		
KC20	1/4" - 2"	ED	KC20/AP (6010-01700)	A-6	6011-41700	D-4	6012-31700	L-0	6013-21700
				A-8	6011-51700	D-5	6012-41700	L-1	6013-31700
						D-6	6012-51700		
						D-8	6012-61700		
KC25	1/2" - 2-1/2"	EE	KC25/AP (6010-02100)	A-6	6011-42100	D-6	6012-52100	L-1	6013-32100
				A-8	6011-52100	D-8	6012-62100	L-2	6013-42100
						D-11	6012-72100		

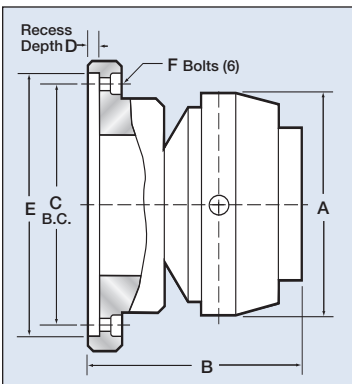

## Dimensional and Performance Data

Chuck Size	KC15/AP	KC20/AP	KC25/AP
A	4.65"	6.00"	6.00"
B	4.56"	5.15"	5.15"
C	5.51"	6.93"	6.93"
D	.15"	.15"	.15"
E	4.921"	6.299"	6.299"
F	M10	M10	M10
Maximum rpm	4000	3000	3000
Weight	16 lbs.	33	30

Other mounting available upon request.