

Front Hand Wheel Speed Collet Chucks

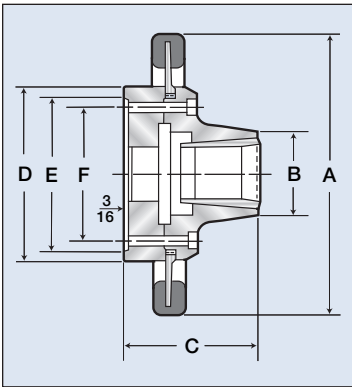

- ⚙️ Fast and easy, front hand wheel operation
- ⚙️ Reduces operator fatigue
- ⚙️ Available for 5C, 2J and 3J collets
- ⚙️ One year warranty
- ⚙️ Accurate-Maximum cone TIR .0005"
- ⚙️ Available in D type (camlock), A type, L type (long tapered nose) threaded, Flat Back and 4° taper
- ⚙️ Hand wheel teeth nitrided for longer life
- ⚙️ Easy installation - no drawtubes or linkages required



Plain Back Chuck Specifications

Item No.	Desc.	Collet Type	Round Cap.	A	B	C	D	E	F	Weight Lbs
PB23-00	5C-PB	5C	1.06	9.0*	2.25	4.25	5.5	5.0	4.12	15
PB24-00	2J-PB	2J	1.37	10.0*	2.62	4.25	6.12	5.75	4.62	19
PB25-00	3J-PB	3J	1.75	10.0	3.12	4.62	6.5	5.75	5.0	23
PB26-00	22J-PB	22J	2.25	10.0	3.62	4.78	7.0	6.25	5.25	28

*Small 7.75" dia. handwheel available without extra charge. When ordering, specify chuck number 5CA or 2JA. This will indicate small handwheel is required.

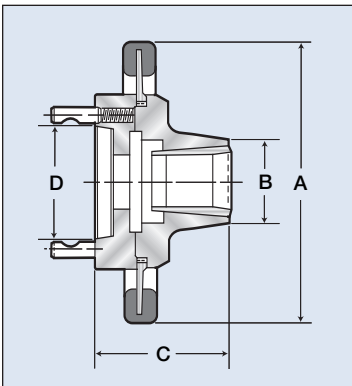

D Type Cam-Lock Chuck Specifications

Item No.	Desc.	Collet Type	Round Cap.	A	B	C	D	Weight Lbs
PB28-00	5C-D1-3	5C	1.06	9.0*	2.25	4.75	2.12	15
PB30-00	5C-D1-4	5C	1.06	9.0*	2.25	4.75	2.5	15
PB31-00	2J-D1-4	2J	1.37	10.0*	2.62	4.75	2.5	15
PB32-00	3J-D1-4	3J	1.75	10.0	3.12	5.12	2.5	23
PB33-00	5C-D1-5	5C	1.06	9.0*	2.25	4.75	3.25	15
PB34-00	2J-D1-5	2J	1.37	10.0*	2.62	4.75	3.25	15
PB35-00	3J-D1-5	3J	1.75	10.0	3.12	5.18	3.25	24
PB36-00	22J-D1-5	22J	2.25	10.0	3.62	5.35	3.25	28
PB37-00	5C-D1-6	5C	1.06	9.0	2.25	4.87	4.18	17
PB37-01	5C-D1-8	5C	1.06	9.0	2.25	5.45	5.5	23
PB38-00	2J-D1-6	2J	1.37	10.0	2.62	4.81	4.18	17
PB39-00	3J-D1-6	3J	1.75	10.0	3.12	5.18	4.18	24
PB40-00	22J-D1-6	22J	2.25	10.0	3.62	5.37	4.18	26
PB41-00	2J-D1-8	2J	1.37	10.0	2.62	4.87	5.5	23
PB42-00	3J-D1-8	3J	1.75	10.0	3.25	5.37	5.5	26

*Small 7.75" dia. handwheel available without extra charge. When ordering, specify chuck number 5CA or 2JA. This will indicate small handwheel is required.

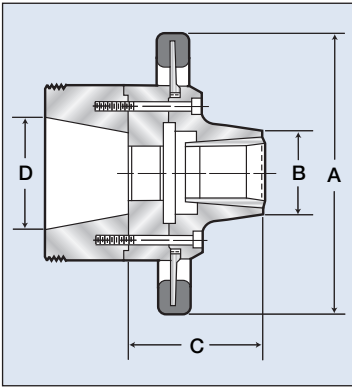

L Type Taper-Mount Chuck Specifications

Item No.	Desc.	Collet Type	Round Cap.	A	B	C	D	Weight Lbs
PB44-00	5C-L00	5C	1.06	9.0*	2.25	6.17	2.75	23
PB45-00	2J-L00	2J	1.37	10.0*	2.62	6.17	2.75	24
PB46-00	3J-L00	3J	1.75	10.0	3.12	6.54	2.75	28
PB47-00	5C-L0	5C	1.06	9.0*	2.25	6.54	3.25	25
PB48-00	2J-L0	2J	1.37	10.0*	2.62	6.54	3.25	26
PB49-00	3J-L0	3J	1.75	10.0	3.12	6.91	3.25	32
PB50-00	5C-L1	5C	1.06	9.0*	2.25	7.04	4.12	26
PB51-00	2J-L1	2J	1.37	10.0	2.62	7.04	4.12	27
PB52-00	3J-L1	3J	1.75	10.0	3.12	7.41	4.12	35
PB53-00	22J-L1	22J	2.25	10.0	3.62	7.57	4.25	35
PB53-0002	5C-L2	5C	1.06	9.0*	2.25	7.57	5.25	34
PB54-00	2J-L2	2J	1.37	10.0	2.62	7.55	5.25	35
PB55-00	3J-L2	3J	1.37	10.0	3.12	7.97	5.25	41
PB56-00	22J-L2	22J	2.25	10.0	3.62	8.0	5.25	46

*Small 7.75" dia. handwheel available without extra charge. When ordering, specify chuck number 5CA or 2JA. This will indicate small handwheel is required.

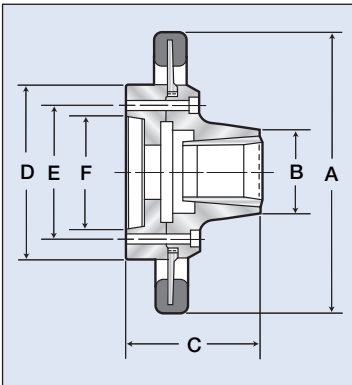

A Type American Standard Chuck Specifications

Item No.	Desc.	Collet Type	Round Cap.	A	B	C	D	E	F	Weight Lbs
PB57-00	5C-A25	5C	1.06	9.0	2.25	4.75	5.5	4.12	3.25	20
PB58-00	2J-A2-5	2J	1.37	10.0	2.62	4.75	6.12	4.12	4.25	20
PB58-3101	3J-A2-5	3J	1.75	10.0	3.12	5.12	6.12	5.25	4.18	20
PB58-3105	5C-A2-6	5C	1.06	9.0	2.25	4.75	5.5	4.12	3.25	25
PB59-00	3J-A2-6	3J	1.75	10.0	3.12	5.12	6.12	5.25	4.18	25
PB59-0002	2J-A2-6	2J	1.37	10.0	2.62	4.75	6.12	4.12	3.25	25
PB60-00	22J-A2-6	22J	2.25	10.0	3.62	5.28	7.0	5.25	4.188	37
PB60-0002	5C-A2-8	5C	1.06	9.0	2.25	4.75	5.5	4.12	3.25	37
PB60-0003	2J-A2-8	2J	1.37	10.0	2.62	4.75	5.5	4.12	3.25	41
PB60-0004	3J-A2-8	3J	1.75	10.0	3.12	5.82	8.125	6.75	5.50	41
PB60-0005	22J-A2-8	22J	2.25	10.0	3.62	5.40	5.5	6.75	5.50	33

*Small 7.75" dia. handwheel available without extra charge. When ordering, specify chuck number 5CA or 2JA. This will indicate small handwheel is required.