



Atlas Workholding Air Powered Front Mount 16C Dead Length Collet Chucks

No Draw-tube or Air Feed Tubes Required: for Lathes, Rotary Tables and Grinders: Series ATL207-16C

Uses 16C Collets see page 114-115

Collet Chuck Order No. with Mount:

ATL207-16CAP

Straight Recess Mount Type A Mount

ATL207-16CA5

ATL207-16CA6

ATL207-16CA8

Type D Mount

ATL207-16CD4

ATL207-16CD5

ATL207-16CD6

ATL207-16CD8

Other Mounts

ATL207-16C44-4° Taper

ATL207-16C45-2³/₁₆-10

ATL207-16C46-2³/₈-6

Collet Chuck Supplied with:

- 2 Filter Bars
- 2 Air Hoses
- 1 Fixing Bracket for Hoses
- 1 16C Collet Wrench
- 1 Hex Key
- Mounting Bolts
- Users Manual

- ⊕ No Hydraulic System Required
- ⊕ No Draw Tube or Air Feed Tubes Restricting Spindle Bore
- ⊕ No Rear Cylinders and Cylinder Adapters
- ⊕ Low Cost
- ⊕ Easily Convert any Lathe or Grinder into a Production Machine
- ⊕ Ideal for Rotary Table Applications
- ⊕ Change from Collet Chuck to Standard Chuck Quick and Easy
- ⊕ High Speed 4000 RPM
- ⊕ High Accuracy Less Than .001" TIR7
- ⊕ Repeats on Duplicate Parts Plus Minus .00015"
- ⊕ Dead Length Design
- ⊕ For Best Accuracy Use High Quality Crawford Collets
- ⊕ Lever or Foot Pedal Actuated
- ⊕ Low Maintenance with Oil Mist Lubrication System
- ⊕ High Resistance to Coolant and Chip Penetration
- ⊕ Uses 16C Collets, Range 1/16" (1mm) to 1-5/8" (42.5mm)
- ⊕ Available in A, D, L, 4 Degree, Threaded and Straight Recess Mounting

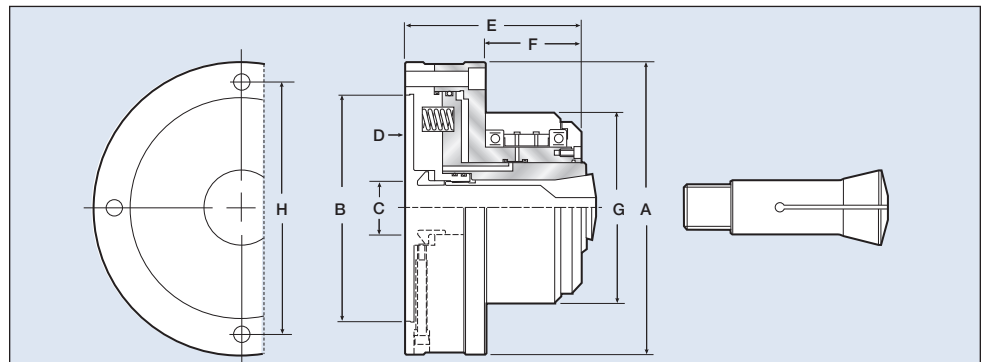

Collet Chuck	ATL207-16C
A	188mm (7.40")
B	150mm (5.91")
C	40mm (1.57")
D	5mm (0.20")
E	112mm (4.41")
F	63mm (2.48")
G	130mm (5.12")
H	168mm (6.61")

Specifications	ATL207-16C
Screw Hole Dia	9mm (0.35") x 4
Collet Type	16C Collets
Max. RPM	4000
Sleeve Stroke	4mm (0.16")
Air Pressure	3-8 kg/cm ² (42-114 psi)
Through Hole Dia	40mm (1.57")
Chuck Weight	14kg (30.8lbs)
Grip Force	12,300 lbs @ 100 PSI

NOTE: "E" shown is for model ATL207-16C Collet Chuck with no mounting plate. Add 3/4" to the "E" dimension for mounting plate. This will vary slightly depending on the mounting required. If an exact "E" dimension is required, consult factory.

OPTIONS: Order No: **LEV100** Lever Control Package: (Includes: Lever Control, Line Filter, Lubricator and regulator.
Order No: **FOT200** Foot Pedal Control Package: (Includes: Foot Pedal, Line Filter, Lubricator and regulator.)